

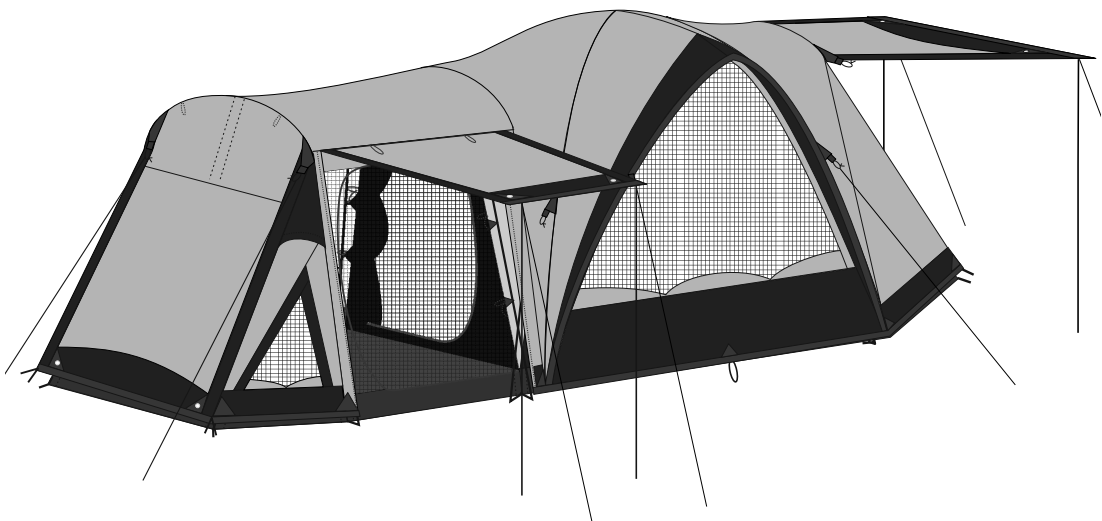

Owners Manual



BREEZEWAY CHALET 4 DOME

www.oztrail.com.au

DTC-BCH4-C

Product Code ~ DTC-BCH4-C

Thank you for purchasing a quality OZtrail product. Please keep this Owners Manual in a safe and dry place, it contains important and helpful information.

IMPORTANT

We recommend that you set up this product before you leave for your trip. Check that all parts are present and that you familiarise yourself with the assembly and disassembly of the product. If you have any questions, your OZtrail dealer will be happy to help you.

The following parts are included for Product Code - DTC-BCH4-C

Part Description

| | |
|-------------------------------------|---|
| <input checked="" type="checkbox"/> | 2 x Main Dome Poles with Burgundy Sticker |
| <input checked="" type="checkbox"/> | 1 x Roof Fibreglass Pole with End Caps |
| <input checked="" type="checkbox"/> | 3 x Vestibule Fibreglass Pole with Grey Sticker |
| <input checked="" type="checkbox"/> | 6 x Portico Steel Vestibule Poles |
| <input checked="" type="checkbox"/> | 2 x Steel Awning Poles |
| <input checked="" type="checkbox"/> | 1 x Pole Bag |
| <input checked="" type="checkbox"/> | 10 x Guy Ropes |
| <input checked="" type="checkbox"/> | 32 x Pegs |
| <input checked="" type="checkbox"/> | 1 x Peg Bag |
| <input checked="" type="checkbox"/> | 1 x Tent Inner |
| <input checked="" type="checkbox"/> | 1 x Fly Cover |

PLEASE NOTE - Due to our policy of continual product development, specifications, parts and features of the product may vary from details within this Owners Manual.

Product And Parts

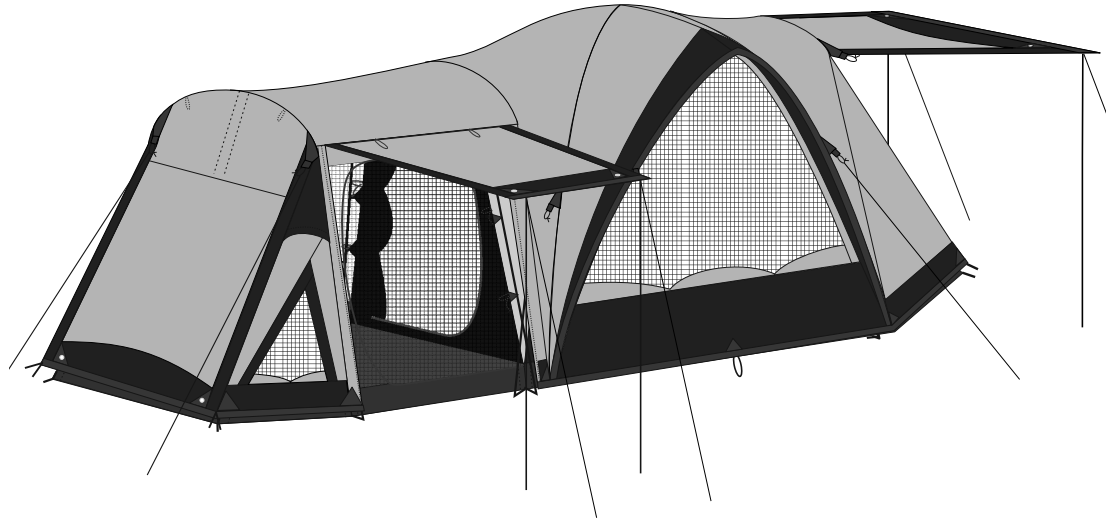



Assembly Instructions

Step 1 Choosing the Site

Select a sheltered camp site protected from the wind that will not allow water to pond under the tent floor. Clear a level area of all stones, twigs, etc.

Step 2 Laying out the tent

Unpack the contents of your tent. Lay out the inner of your tent in the direction you wish it to face. Ensure that you have the door facing in the direction you desire.

Step 3 Peg down the tent

Peg out the corners of the inner tent. These peg points are indicated in Figure 1. Anchor the tent to the ground by inserting the pegs through the loops around the base of the tent at an angle of 45 degrees as indicated in Figure 2. Firm but not tight.

Step 4 Assemble the poles

Assemble all poles making sure each pole junction is securely connected. Place the assembled poles side by side for easy identification.

Step 5 Standing up the tent

Select the two long main fibreglass poles with burgundy stickers and place them diagonally across the main apex of the tent from corner to corner sliding them through the pole sleeves with burgundy trim. With the help of another person, connect the pole ends onto the corresponding pin and ring assemblies at the base of the tent. Allow the poles to bow into their natural curve at this stage. While holding the pole in position, beginning at the base and working your way towards the apex of the tent, clip the J Hooks of the inner tent onto the pole. The tent will stand up during this step, see figure 3.

Step 6 Installing the roof pole

Select the roof fibreglass pole with end caps. Position the pole over the apex of the tent and lay it from side to side, see figure 3. Connect the J hooks on the inner tent to the pole and use pole tie to secure all poles at the apex.

IMPORTANT

- 1. After unpacking the tent, use the check list on page 2 to make sure you have all the parts.**
 - 2. You need to condition your Tent / Shelter before use.**
- See the following section, Conditioning your new Tent / Shelter**



Assembly Instructions

Step 7 Installing the vestibule poles

Select one of the vestibule fibreglass poles with grey sticker and install by sliding it through the pole sleeve with the grey trim on the pole sleeve that runs across the top of the front door, see figure 3. Insert the ends of the vestibule fibreglass pole into the narrow opening of the 2-way hubs that are pre-attached to the tent.

Repeat this process for the second vestibule fibreglass pole with grey stickers and slide through the sleeve with grey trim that runs across the tent above the internal room divider wall. Select the remaining vestibule fibreglass pole with grey stickers and slide through the sleeve with grey trim that runs across the top of rear door, see figure 3. Select one of the Portico steel vestibule poles, insert an end into the remaining opening of the 2-way hub and insert the opposite end of the pole onto the corresponding Pin and Ring assembly at the base of the tent. Repeat this process for the remaining five Portico steel vestibule poles. The front and rear of the tent will stand up during this process. Connect the J-Hooks attached to the inner tent onto the poles. Peg out all remaining peg points around base of tent.

Step 8 Attaching the Fly Sheet

Lay the fly sheet out along the side of your tent. Ensure that you have the front and the back aligned correctly. Raise the fly sheet up and carefully draw it over the top of your tent. Do this slowly to avoid snagging the fly. Once the fly sheet is on top of your tent locate the webbing pockets inside the fly at the top of the side window openings and place the ends of the roof fibreglass pole with end caps into these pockets on both sides of the tent. You can now securely attach all of the Posibrace™ Velcro™ reinforcing points on the underside of the fly sheet around the corresponding poles and hubs. Now connect the hooks along the base of the fly to the corresponding ring around the base of the inner tent.

Step 9 Guy ropes and peg out

Ensure all guy ropes and peg points of the fly and tent are utilised. Make a loop (about 30 – 50cm long) with a slider on the end of the rope and peg out as far as possible from the tent. Ensure all guy ropes are attached firmly and remain firm, see figure 4. If required use the remaining steel awning poles to set up front, side or rear awnings.

PLEASE NOTE: In severe conditions the tent should be dismantled

Figures And Illustrations

Figure 1

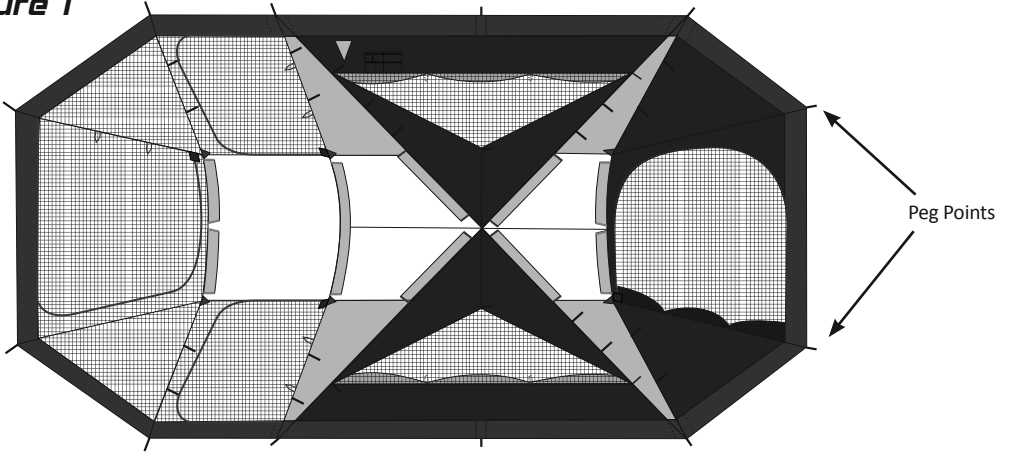
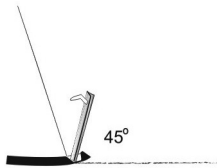

Figure 2



Figures And Illustrations

Figure 3



Figure 4

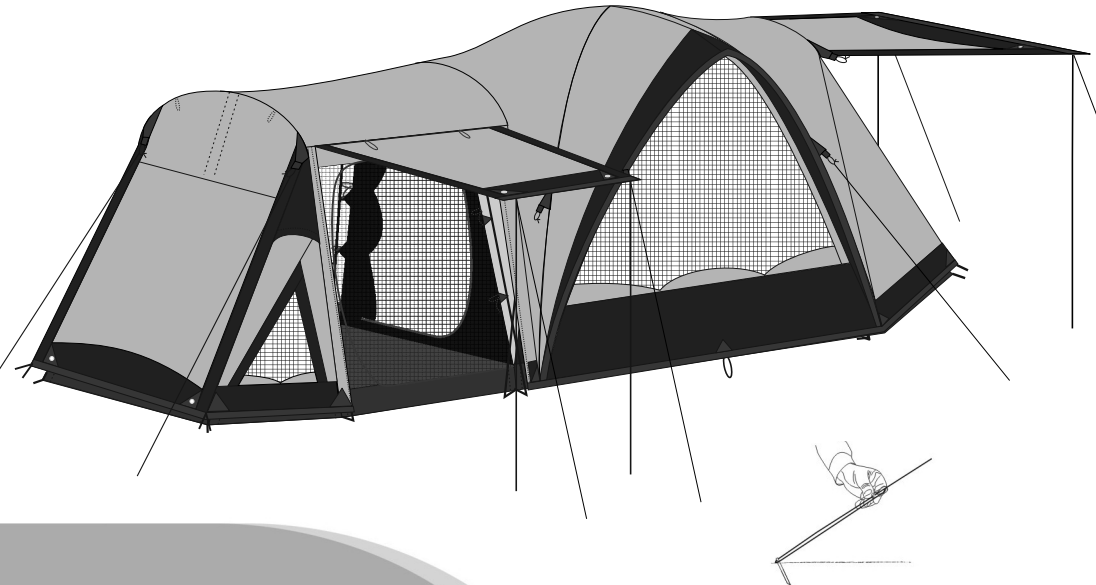

Disassembly Instructions

Step 1

On the fly close windows, awnings and doors, release guy ropes and Posibrace™ Velcro™ points that attach the fly to the poles and unhook all base hooks. Disconnect the roof pole from both sides of the fly. You can now remove fly from tent. Lay fly flat on ground and fold fly in half, third or quarters. The width of the folded fly should be the length of the pole bag. See diagram opposite page.

Step 2

Unzip doors and windows, collapse the tent by removing and disassembling the poles in the reverse order of the assembly instructions. Place the poles in the pole carry bag and tie shut.

Step 3

Remove pegs with a claw hammer or peg puller. Do not remove pegs from the ground by pulling on tent base as this may cause damage to the tent.

Step 4

Spread the tent out flat with all loose fabric folded within the edges of the tent base. Try to flatten the tent as much as possible.

Step 5

Fold the tent in half, third or quarters. The width of the folded tent should be the length of the pole bag. See diagram opposite page.

Step 6

Lay the folded fly over the folded inner tent. Beginning at the back portion of the Fly and inner tent bundle roll forward firmly allowing trapped air to escape. It may help to use the bag of tent poles as a rolling pin ensuring the tent edges are kept straight as you roll.

Step 7

Once the tent bundle is rolled up, tie straps around it and place into tent carry bag with peg bag, instruction booklet and other miscellaneous parts. If the tent won't fit into carry bag, unroll and reroll more tightly.

Important

Do not store your tent damp or dirty. If you have no choice but to return home from your camping trip with a damp or dirty tent, make sure you lay it out to air in a cool, dry and shaded place and only pack it away when it is completely dry and clean.

Folding Instructions

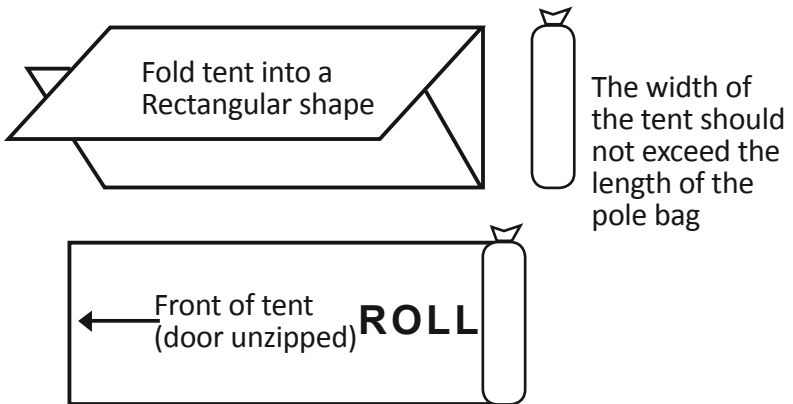



Warranty

OZtrail tents are warranted for a period of two years from date of purchase. The manufacturer agrees during the warranty period to repair any manufacturing defects in the product or, at its option, replace the product with another product or an equivalent product without cost to the owner for material or labour.

This warranty is subject to the original proof of purchase and the products being used in accordance with the instruction manual.

Important: This tent is to be assembled once before going camping to ensure that all parts are present and to become familiar with the assembly of the tent.

This warranty does not cover defects due to modification, accident, damage caused by vandalism, rusting, acts of nature or any other event beyond the control of the manufacturer. Nor does this warranty cover scratching, scuffing, natural breakdown of materials that occur inevitably with extended use including Ultra Violet light damage and exhausted zippers or other cosmetic damage that may result from normal wear and tear. In addition, defects resulting from intentional damage, negligence or unreasonable use will void this warranty.

If the product is defective within the terms of this warranty, OZtrail will repair or replace defective parts at no cost to the purchaser. Please note the shipping charges to and from the OZtrail warehouse or original place of purchase are not covered under warranty and are the responsibility of the purchaser. OZtrail reserves the right to make substitutions to warranty claims if parts are unavailable or obsolete.

Your product is valuable and should be insured against loss or damage. During strong winds and storms collapse the tent flat onto the ground and seek refuge in your vehicle. Damage caused by storms and strong winds is not covered by warranty.

This warranty does not cover incidental expenses including property damage.

EXTREME CAUTION - Gas, fumes or lack of oxygen within the tent/shelter could result in unconsciousness, brain damage and even death

Important Safety And Care Information

PLEASE READ BEFORE SETTING UP YOUR TENT/SHELTER

CAMP SAFE - SAFETY HABITS

The fabric may burn if left in continuous contact with a flame from any source. Also, the application of any foreign substance to the tent fabric may render the flame resistant properties ineffective.

To prevent injury caused by gas poisoning or suffocation -

- Do not use fuel burning, oxygen consuming devices inside the tent. This includes candles, gas lanterns, kerosene lamps, stoves, cooking and heating appliances
- Do not use gas appliances of any kind inside the tent/shelter

To prevent injury caused by fire -

- Do not pitch the tent/shelter near a camp fire or any other flame source
- Do not use candles, matches or any other flame source in or near the tent (this includes stoves, cooking equipment, lighting and heating appliances)
- Only use recommended water repellent compounds on the tent/shelter fly
- Do not spray tent fabrics with insecticides



To prevent injury caused by electricity -

- Always exercise care when using electricity and electric lighting in and near tents/shelters. Only use 12 volt lighting.



To prevent injury caused by your camping environment -



- Do not pitch your tent/shelter on an area that could get flooded



- Do not pitch your tent/shelter near cliffs in case of collapse or rock fall



- Do not leave your tent/shelter erected in strong winds - collapse the tent onto the ground and seek refuge in your vehicle



- Do not pitch your tent/shelter under trees with dead branches or under trees known to drop branches



Prolonging The Life Of Your Tent/Shelter

- Temporary use only. Although our fabrics are treated for extra UV resistance, continuous exposure to sun light will break the fabric down. Fading of colour is an early warning sign. OZtrail products are not designed as permanent dwellings or structures.
- During rain always lower awnings to avoid water ponding.
- Never store a wet and/or soiled tent/shelter; as mildew and corrosion can form within a few days. This condition is not covered by the warranty. Always allow the tent to dry completely before packing and stowing. If mildew occurs, use a soft bristle brush or sponge with mild detergent to clean it off. After beach use or wet weather treat all zips, poles and pegs with silicon spray
- The elastic shock cord within the poles is provided for easy assembly of the poles. The shock cord is not required for any structural reason. The poles and tent perform perfectly well without the shock cord. Age, over stretching and mishandling may cause failure. Shock cord is not covered by warranty. It's easy to replace, see following instructions.
- Sometimes the zipper coil bursts open or does not close. This could be due to wear or metal fatigue. The problem can be easily fixed, see instructions that follow.
- Always carry a roll of heavy duty tape for simple repairs to small rips, cuts and ash burns. This not only blocks the hole, it will prevent further tearing. Heavy Duty tape is also helpful for emergency pole repairs and many other uses around the camp site.
- When removing pegs, do not use the webbing or corner of the tent as your handle. Either use another peg, a peg remover or the claw of a hammer hooked under the peg to remove them.

IMPORTANT - CONDITIONING YOUR NEW TENT

Once you get your new tent home, it is important to condition the tent. Simply pitch your tent and wet it down with your garden hose. Pay particular attention to the seams - the thread swells when wet and blocks the needle holes. The needle holes also shrink around the thread. The fabric also benefits from this because the fibre swells into the weave and the waterproof treatment settles within the fabric. Let the tent dry completely before doing it a second time. Always pack your tent away dry.

Understanding Waterproofness

What is not covered by warranty!

OZtrail tents use waterproof and water repellent fabrics. However, with the addition of seams, zips and other desirable features a recreational tent will not be as waterproof as a car, house or other solid structures. The following are common examples of how water can enter a tent: -

Condensation - When warm moist air meets cooler air, condensation occurs. The tent/shelter fly forms an impermeable layer between the inside and outside conditions. The moisture inside the tent/shelter condenses on the fabric. Sometimes in cold conditions it appears that the fabric is leaking when in fact the cause is condensation. Condensation can be reduced if the tent/shelter is well ventilated.

Zips - All care is taken in the design to cover zips with rain flaps. At times wind driven rain could force water under the rain flaps and through the zips. To minimise this, make sure all doors and windows are closed with the rain flaps covering the zips.

Floor - If the ground is very wet or water pools under the floor, downward pressure of standing or kneeling on the floor could force water through the floor fabric. To prevent this, do not pitch the tent over hollows and make sure water drains away from the tent.

Structural Integrity - A perfectly pitched tent on perfectly flat ground is structurally strong and most waterproof. During prolonged periods of rain and wind it may be necessary to tighten guy lines and reset the tent pegs and attend to drainage around the tent. Sagging and incorrect pitching weakens the tent structure and could allow water to pool on the fly placing undue forces on the tent causing leaking and breakages.

Replacing shock-cord in tent poles

Use this procedure to replace broken or untied Shock-Cord:-

1. Start by cutting the Shock-Cord to two thirds of the length of the Tent Pole
2. Feed the cord through the first pole section and tie a double knot. The knot will catch on the end of the fibreglass pole inside the ferrule.
3. Stretch the Shock-Cord through each Pole Section keeping the cord stretched within the poles so you have enough relaxed cord to feed through the next Pole Section.
4. Once all Pole Sections are threaded, double check that the Shock Cord tension is not either too loose or too tight and then tie-off the free end.

Shock-cord can be purchased by the metre from Camping Stores or with Pole Repair Kits.

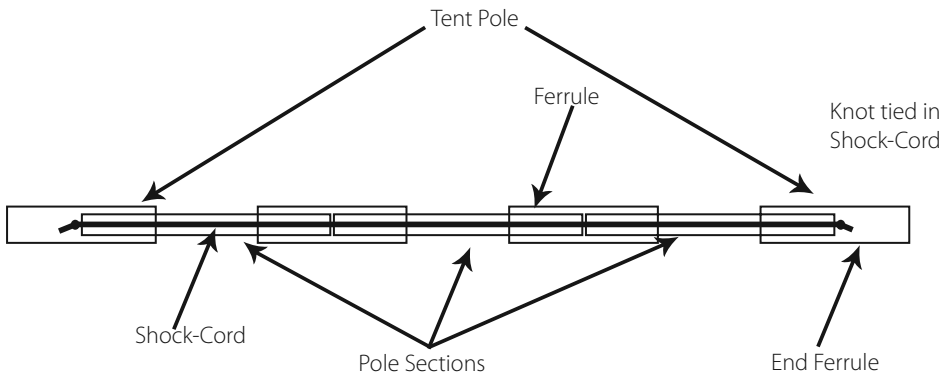

Zips

Reducing the risk of jamming fabric in the zip ~

- When using the zip, hold the pull-tab between your thumb and forefinger with your thumb facing you.
- As you are closing the zip clear the way in front and under the zip slider using the back of your hand, and cup the zip slider underneath with your remaining 3 fingers.

Use this action for opening or closing. Keep the fabric clear of the zip slider - zip and unzip slowly.

What to do if the zipper gets caught ~

- Pull the fabric bit by bit out of the slider. Do not try and pull all the fabric in one go. Do not force the slider or the fabric.

If the slider does not close the zipper properly ~

- With use, the jaws of the zip slider can open ever so slightly. When this occurs the slider does not compress the zip teeth or coil together tightly enough and the zip bursts open or does not close.
- Undo the zip and with the slider at the end of the zip lightly crimp the jaws of the slider together. Try top to bottom axis first and then side to side axis.

Crimping A Zip-Slider

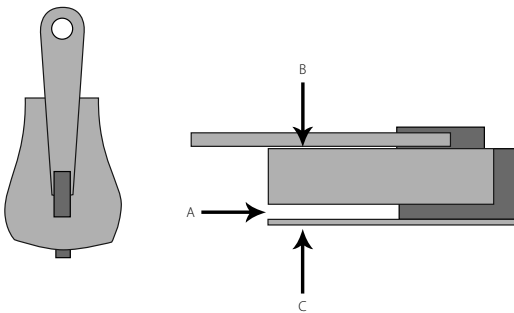

The most common reason why zips burst open is that the zip slider does not close the coil tightly enough. Wear and tear may cause the gap marked A to open up.

By simply 'crimping' the slider together at points B & C with a pair of pliers, this solves the problem most of the time. Crimping in other planes is worth a try if B & C does not work. This is to be done when the zip slider is still attached to the zip in the open position.



Check out www.oztrail.com.au
for other great products from OZtrail Leisure Products



Imported by:
OZtrail Leisure Products
PO Box 1, Sumner Park QLD 4074
www.oztrail.com.au
Made in China